

BridgeCom SYSTEMS

Connecting the ComLink CS-540 to the IDA RLC Logic Controller

By: Ron Kochanowicz
 Bridge Embedded Systems, Inc.
 Email: Ron@BridgeEmbeddedSystems.com

INTRODUCTION

The versatility of the CS-540 repeater allows for it to be controlled by an external peripheral such as an LTR® controller. This application note describes how to connect the ComLink CS-540 to the popular IDA RLC repeater logic controller. In addition, many of the CS-540's features are highlighted to show how it can be used to better serve you in a trunking system.

CONNECTIVITY

The CS-540 comes with a 25pin female D-SUB connector on the rear of the unit. This connector supports all the I/O required for a clean one-cable connection from the RLC to the CS-540. Figure 1 diagrams the connections of each male connector:

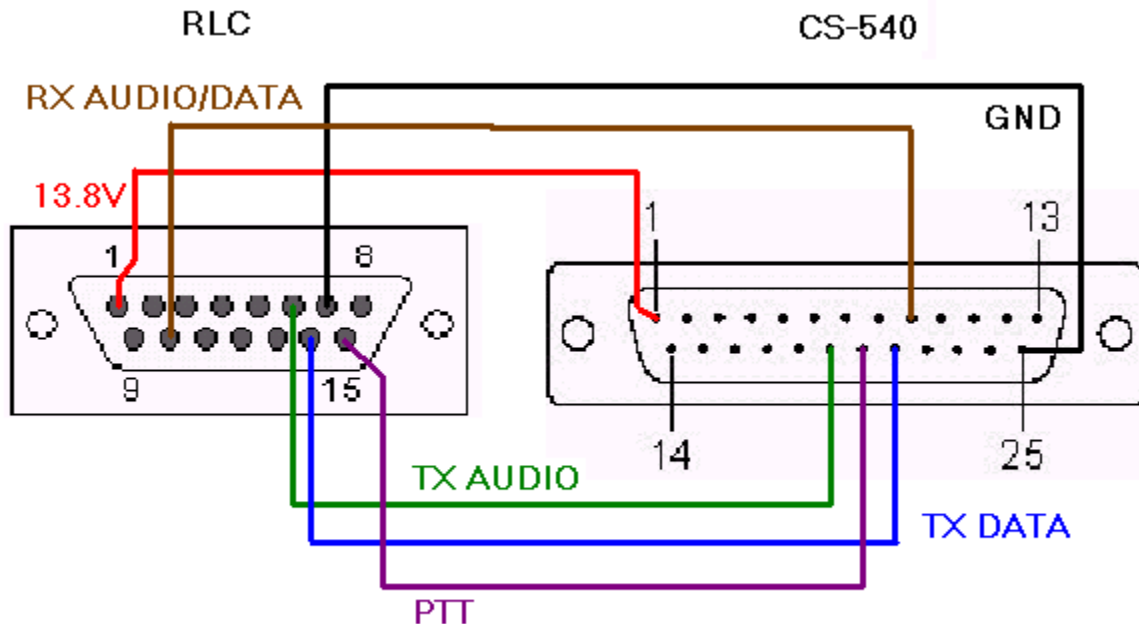

Figure 1: Connectivity Diagram

CONNECTION	PIN – RLC	PIN – CS-540
GROUND	7	25
POWER – 13.8V	1	1
TX Audio	6	19
TX Data	14	21
RX Audio/Data	10	8
External PTT	15	20

To achieve these connections a custom built cable is to be constructed. This cable can be purchased by BridgeCom Systems, or you can easily build it yourself. To build the cable a six-conductor shielded cable and one male 25pin DSUB connector and one male 15pin DSUB are required. It is recommended the cable be made as short as possible. All of the connections are simple and straight through. The shield is to be connected to ground.

REPEATER SETUP AND OPERATION

Program the CS-540 for the TX/RX frequencies it is to operate on. Once all the cable's connections have been tested, connect the CS-540 to the RLC. Power the repeater and observe the CS-540 going through its power-up sequence and verify power is being supplied to the RLC. Using the keypad, select the channel the CS-540 is to operate on. Restore the factory defaults for the transmitter by pressing and holding the AUX button for approximately two seconds. Once DEFAULT is displayed, press-and-release the UP or DOWN button. When the word DONE is displayed, press-and-release the AUX button to return to repeater mode. Press and release the AUX button to place the CS-540 in auxiliary mode. The RLC is now controlling the CS-540.

The DC level of the RLC data output is approximately 4.5 Volts DC. The CS-540 requires the DC data level to be 2.5 Volts DC. To match the levels, the CS-540 has a level shifting trim-pot located on the internal accessory board. Open the CS-540 and locate P1. Place a DC voltmeter on TP1 and adjust the trim-pot until the voltage reads 2.5 DC.

Follow the RLC installation manual for aligning the controller to the CS-540. **On the RLC, leave JP23 and JP24 uncut.** The CS-540 does not require pre-emphasized audio. The CS-540 will indicate it's receiving carrier by illuminating the yellow LED. The CS-540 will indicate it's transmitting by illuminating the red LED.

Once the data levels are set and the radio's fail to handshake with the controller, I have found most times that it is due to one of the following: improper setting of the area bit, RX polarity, or TX polarity.

Once the alignment is complete, it is recommended to check the data DC level at TP1 to ensure it is 2.5 Volts DC prior to closing the unit.

FEATURE HIGHLIGHTS

- **LTR DECODER**
The CS-540 has a built-in LTR decoder. This diagnostic tool allows for viewing the home channel and ID of the call being repeated. This feature is activated during AUX mode by pressing-and-releasing the BASE button. The LTR decoder is active when the LCD displays 'd-----'.
- **CHANNEL MONITORING**
You can monitor the audio traffic on the repeater channel by activating the repeater's built-in front panel speaker. To activate the internal speaker simply press-and-release the MON button. The internal speaker is active when the NOTE icon is displayed.
- **BACK-UPS**
Since the CS-540 supports up to 16 channels, it offers a convenient way to back-up almost all of your repeaters in your trunking system. By simply programming and naming all the channels, you now have a back up in the event a key repeater should fail. Please remember: For all the channels you program, you need to perform the simple procedure to restore the factory defaults for each channel. See the CS-540 owner's manual for more information.